

SIGNALING NETWORK OPERATIONS SYSTEM (SIGNOS) IN KOREA

Misoon Kim, Sanghwan Kung, and Younghee Lee

Electronics and Telecommunications Research Institute
P.O.Box 8, Daedog Danji, Daejeon, KOREA

ABSTRACT

The paper describes an operations system newly designed to establish the network management and provisioning functions for CCS(Common Channel Signaling) network being currently deployed in Korea. The SIGNOS, which is a sort of centralized system to accommodate a number of SMX-1s(Signaling Message Exchange), so called STP, consistently monitors and maintains CCS network in the network wide point of view to assure efficient utilization of the network. The key issue here in this paper is to introduce the system architecture and functions of SIGNOS and to present an example of interface between an operations system and network elements. In order to resolve the interface between SMX-1 and SIGNOS we apply a part of SMX-1 itself to the front-end of SIGNOS, anticipating that No.7 protocol will be suitable for signaling network management in the future.

1. INTRODUCTION

The CCS network supports a wealth of conventional and advanced telecommunication services as a backbone for IN(Intelligent Network) and ISDN(Integrated Services Digital Network), carrying services and features between switching systems and databases as well as call control messages between switching systems. To construct CCS network and IN in this country we are presently giving our exertion to develop SMX-1, which is major component of CCS network, in accordance with CCITT recommendations and domestic specifications, and to realize IN services such as free phone service and credit card calling service. Since CCS network conveys important signaling informations in telecommunications network, it should be stable with the high performance and its activity be surveillanced all the time. The SIGNOS, which plays the role of operations support function for signaling network, concerns not only network management based on measurement data pertaining to performance, utilization, and availability of signaling network, but also configuration management maintaining the information about signaling points, signaling links, and signaling routes.

2. CCS NETWORK ARCHITECTURE

2.1 CCS Network Configuration

The CCS network, which is comprised of a number of SPs(Signaling Point) and signaling links, delivers signaling messages with the high speed and high reliability between various SEPs(Signaling End Point) such as SSP(Service Switching Point), SCP(Service Control Point), STP, SDMS(Service Data Management System), and SIGNOS.

Looking at the CCS network in the view of providing IN service, SSP communicates with SCP to access information for network services by means of SCCP(Signaling Connection Control Part), TCAP (Transaction Capabilities Application Part), ASE (Application Service Element) protocol. SCP maintains informations concerning intelligent services, retrieves requested informations from the database, and supplies them to SSP through the CCS network. The STP, which has the mediation function between SPs as a packet exchange, could be a SEP when it has the user application part. To enable customers to access their own service informations, SDMS keeps data related to specific service, interfaces customers and allows them to control service informations. The alarm and fault informations generated from SSP, STP, SCP are collected to CSMS

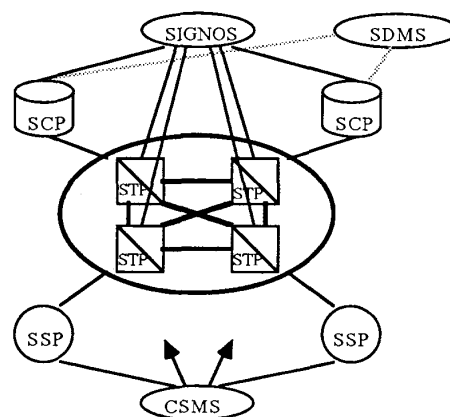

<Fig.1> CCS Network Architecture

31.5.1.

(Centralized Switching Maintenance System) and notified and analyzed for maintenance personnel to recover the trouble as soon as possible.

In parallel with executing some components of CCS network, the regulation of national standards for No.7 protocol like MTP(Message Transfer Part), SCCP, ISUP (ISDN User Part), TUP(Telephone User Part), TCAP is in process presently.

To be suitable for our domestic environment on planning signaling network, some of policies mentioned below are being taken into account:

- CCS network has one-level based, two-level according to circumstances, hierarchical architecture
- The connection between STPs is full-meshed
- The signaling links between SPs comply with quasi-associated mode

2.2. SMX-1 System

SMX-1 to be designed with high performance and large capacity has a distributed multiple processor architecture as depicted in <Fig.2>. It consists of four subsystems such as MTPS(MTP Subsystem), OMS (Operation and Management Subsystem), TMS(Test and Maintenance Subsystem), and SIS(Subsystem Interconnection Subsystem). In order to attain efficient implementation the OMS and TMS are being handled under commercial computer system because they are not directly related to the signaling message processing and require facile database manipulation and convenient I/O device operation. On the other hand, both hardware and software for MTPS, which is made up of several SMH (Signal Message Handling) modules and one SNM(Signal Network Management) module, are being developed in

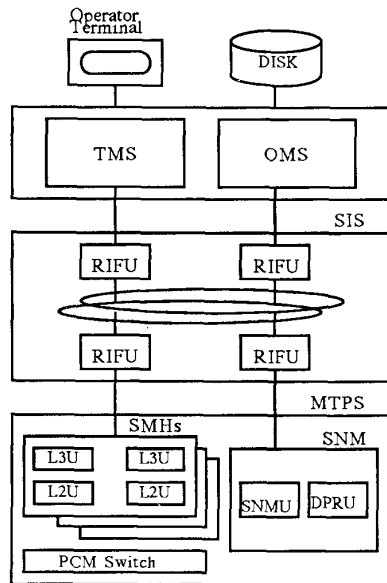

<Fig.2> SMX-1 Architecture

the laboratory. The internal data transfer between subsystems is carried out in SIS through the FDDI(Fiber Distributed Data Interface) token ring, which establishes a fault-tolerant high speed message transfer capacity with 100 Mbps. The aimed service with this architecture of SMX-1 is as following:

- i) System Performance
 - 10,000 messages per second
 - 20 ms Mean Response Time
 - Capacity of 512 signaling links
- ii) Reliability and Availability
 - 0.99998 availability (signaling routing set)
 - 2 hours MTTR(system)

3. SIGNALING NETWORK OPERATIONS SYSTEM (SIGNOS)

3.1. System Functions

The scope of SIGNOS functions is primarily referred to the CCITT recommendation Q.791 and Q.795 (Signaling system No.7, Monitoring, Operations and Maintenance). Some of functions which SIGNOS should offer to its users are categorized into four, which are data gathering and monitoring, network provisioning, statistics reporting, and network dimensioning.

Data Gathering and Monitoring

The measurement and surveillance data are generated from each node of CCS network, SMX-1, and stored into the database of SIGNOS. The collected data are used for analyzing not only node status but also network status. The message which SIGNOS collects from the signaling network represents performance, availability, and utilization of signaling link, signaling link set, SP, signaling route, and SCCP, as well as internal performance measurements of SMX-1. The data collection is done by scheduling for periodical measurements, by on-demand for configuration data reference, and by on-occurrence for emergency event notification. As soon as the emergency situation, such as network congestion over threshold value, routing failure, and abnormal status of network resources, is reported to SIGNOS, its message is indicated on the operator terminal and its event is displayed on the graphic monitor with the overall signaling network. No matter when the SIGNOS operator wants to look up the gathered message, he can refer to stored message from the database. Although SIGNOS is not much interested in controlling the network, it can update threshold value used for congestion detection and timer value of MTP for network control and synchronization.

Network Provisioning

The signaling messages between SPs are delivered by means of diverse routing tables which SMX-1 retains. Accordingly, table contents always should be kept correct and integrated in the network. Here are some of routing tables SMX-1 makes use of.

- Signaling point table
- Signaling link table
- Signaling link set table
- RIFU(Ring Interface Unit) table

31.5.2.

- GTT(Global Title Translation) table
- Subsystem table

SIGNOS supports the operator to change routing tables in a convenient way with the menu driven and form management function whenever there happens a change of the network configuration. All of data entered by the operator, who wants to add, update, delete, and retrieve single entry or group entries of the table, are validated to confirm the data correctness and sent to remote SMX-1. The table update data sent to SMX-1 are actually processed in two ways. They are immediate execution and delayed execution. By immediate execution the update is done no sooner than the SMX-1 accepts the data. On the other hand, by delayed execution the update is done on the designated time or when the successive activation command is arrived.

In addition, it offers the function to copy the whole contents of the routing table to validate correctness and completeness between paired SMX-1s or SMX-1 and SIGNOS.

Statistics Reporting

The reporting is just the task for the network administrator to catch a glimpse at the overall network operational status. Both activities of specific nodes and internodes in the signaling network could be analyzed in detail by the reporting function with the help of message database kept for a long period. By the operator's request on demand the reports are generated and, additionally, they could be made on the specified time by the operator's scheduling. The statistics and reports which SIGNOS produces are classified as following.

- Operations and maintenance analysis report
- Traffic statistics
- Network configuration status
- Routing table change report

Network Dimensioning

The traffic data accumulated in the previous term are used for planning the future signaling network. The network planning starts with forecasting signaling traffic by evaluating the previous traffic and recognizing the traffic pattern in the present network. The result of signaling traffic forecasting with the other related informations such as forecasted voice traffic volume and anticipated customer demands for lots of telecommunications services is utilized for making a decision regarding the number of network resources like STPs and signaling links.

3.2. System Architecture

SIGNOS is composed of two parts, application processing part and application support part. In application support part there are four subsystems, which are NIS(Network Interface Subsystem), UIS(User Interface Subsystem), SMS(System Management Subsystem), and DMS(Data Management Subsystem), and in application processing part there are TPS(Transaction Processing Subsystem), NMS(Network Management Subsystem), CMS(Configuration Management Subsystem), and NPS(Network Planning Subsystem)

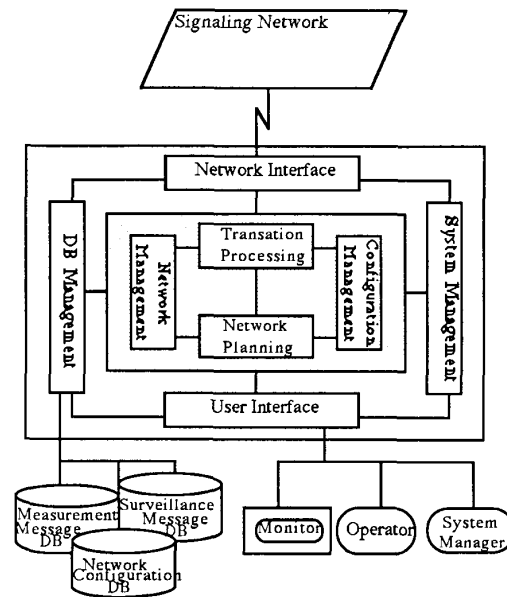

<Fig.3> System Architecture

NIS (Network Interface Subsystem)

NIS, as a front-end processor, has a direct connection to each SMX-1 to exchange measurement, operations and maintenance messages between SIGNOS and SMX-1, and processes CCITT No.7 low layer protocol like MTP, SCCP for communication with SMX-1. As a strategy to implement No.7 low layer protocol efficiently we are planning to make avail of SMX-1 itself which is being developed in the same laboratory.

UIS (User Interface Subsystem)

UIS assists the operator to access SIGNOS by means of CRT terminal, personal computer and graphic monitor. with some features for command input, graphic display, and report generation, The menu handler, input data validator command scheduler are established for user command processing, alarm handler and network configuration displayer for graphic display, report scheduler and report form designer for report generation.

SMS (System Management Subsystem)

The role of SMS is to manage and maintain SIGNOS itself and its environment. Before operating SIGNOS, its software and database should be installed and all of application programs should be run, and also in operation the process status ought to be monitored. Besides, SMS offers system and network maintenance functions by logging errors and provides the means of direct communication between SMX-1 and SIGNOS.

DMS (Data Management Module)

The databases regarding signaling measurement, network surveillance, network configuration, and configuration change are manipulated by SIGNOS users and application programs. DMS gives users and programs

31.5.3.

some methodologies for database access. Therefore a user can obtain requested information from the databases with the help of application programs or directly with the support of DBMS. In SIGNOS how to store data of different nodes and different kinds is important because they are utilized for analyzing both network status and node status. Except for database related to remote SMX-1 there are some local criteria for command scheduling, message identification, and data collection.

TPS (Transaction Processing Subsystem)

The messages between SMX-1 and SIGNOS are exchanged through NIS. NIS takes charge of low layer protocol, on the other hand, TPS located at the back of NIS processes high layer protocol. Even though SIGNOS application requires transaction processing and file transfer capabilities, the message processing module of TPS, a kind of ASE upon TCAP, handles short and long messages for both purposes in stead of FTAM(File Transfer, Access and Management) and functions message segmentation and message envelopment.

NMS (Network Management Subsystem)

NMS has the role of data collection, network surveillance, and partially network control as described in SIGNOS functions. A number of reports for traffic, performance, and maintenance analysis of the signaling network as well as STP performance analysis are also made in NMS.

CMS (Configuration Management Subsystem)

The network provisioning is deeply concerned by CMS with the functions of table update, table inquiry, table verification, and table copy. CMS furnishes network facility reports and table change reports to SIGNOS users.

NPS (Network Planning Subsystem)

A personal computer will be allocated for NPS because NPS mainly regards long term analysis and needs to use specific package for network planning. The network activity evaluation, signaling traffic forecasting, and signaling network dimensioning are counted on as major functions of NPS.

3.3. System Interface

The low and high layer protocols for signaling network management are under study in CCITT. As standard protocols for CCS network management, MTP and SCCP for low layer protocol and TCAP or OSI ROSE(Remote Operation Service Element) for high layer protocol are being discussed.

Now we take account of using No.7 protocol for interface between SIGNOS and network elements in the CCS network, by taking a part of SMX-1 as the FEP (Front-End Processor) of SIGNOS. Therefore, SMH module, which has L2U of MTP level 2 function and L3U of MTP Level 3, and SNM module are located in FEP. This FEP has point-to-point connections to remote SMX-1s, assigning two links for backup in case of failure, and the communication between FEP and BEP (Back-End Processor) is done by general computer communication interface, for instance RS-232C. Why we

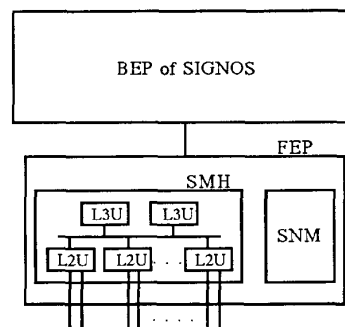

a. Interface Architecture

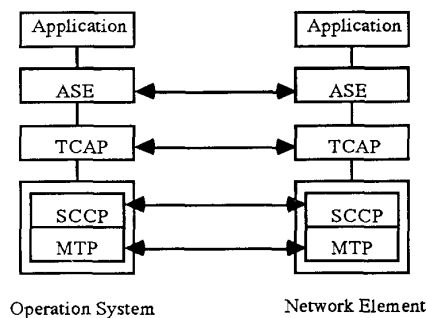

b. Protocol Architecture

<Fig.4> System Interface

consider point-to-point interface is mainly dependent on apprehension of the failure which may happen in CCS network.

4. Conclusion

We have developed various operation systems being operated for our telecommunications network, which are SLMOS(Subscriber Line Maintenance and Operations System), TLMOS(Toll Line Maintenance and Operations System), and CSMS(Centralized Switching Maintenance System). Making the most of these development experiences, we are now observed in accomplishing SIGNOS for CCS network.

The SIGNOS project is in the first year of development and its overall architecture and system functions are currently being set up. As a first activity in the laboratory, implementation of No.7 upper layer protocol such as TCAP and MRVT(MTP Routing Verification Test) of OMAP upon MTP and SCCP is being carried out. By performing this task we expect to acquire deep understanding for deployment of No.7 protocol, although MRVT is not necessarily required on condition that all SPs do not have OMAP also.

Since SIGNOS demands various and plenty of

database access, commercial DBMS will be more favorable than developing specific database access function. With the advantage of portability of UNIX O/S, SIGNOS could be ported to large computer system according to the capacity requirements for SIGNOS field environment after it's been developed under a small system in the laboratory.

5. REFERENCES

- [1] Kazuhiko Ogawa and Hiroshi Shimizu, "The Operation System for Common Channel Signaling Network in Japan", IEEE Singapore ICCS'88. 1988.
- [2] L.R.Bowyer and M.I.Almquist. "The Signaling Engineering and Administration System", CH2298.9/86/000-1325 1986 IEEE.
- [3] Y.H.Lee, J.K.Choi, C.H.Yim, J.R.Yoon and S.B.Lee, "Design of A Large-Scale Signaling Transfer point (STP) for CCITT No.7 Common Channel Signaling Network in Korea", ICCS '89.
- [4] M.M.Kaplan and D.W.Tietz, "Design and Implementation of Integrated Operations Support", CH2431-5/8/7/0000-0166, 1987 IEEE.
- [5] Julio C. Locez, "CCS7 Based Operational Support System(OSS-7) Network Architecture", CH2298-9/86/0000-1008 1986 IEEE.
- [6] Hoon Choi, Youngsik Back, Kyesang Lee and Yanghee Choi, "Specification and Testbed Implementation for CCITT No.7 Signaling System in Korea", Computer Communication Technologies for the 90's, J.Raviv(Editor), Elsevier Science Publishers B.V.(North-Holland) ICCS 1988.

31.5.5.